

*Adiabatic
humidifier*



NEB 6500

The NEB 6500 is a room humidifier that nebulizes water by centrifugal force. It's completely self-contained and needs only connection to the power supply, water main and a drain hose. The working principle and the simple but sturdy assembly allows the NEB 6500 to work with any kind of tap (drinkable water from the municipal network) or demineralised water. It produces a fine mist that will immediately evaporate into the room to be humidified. Available also with heating resistance.



Adiabatic humidifier



NEB 6500

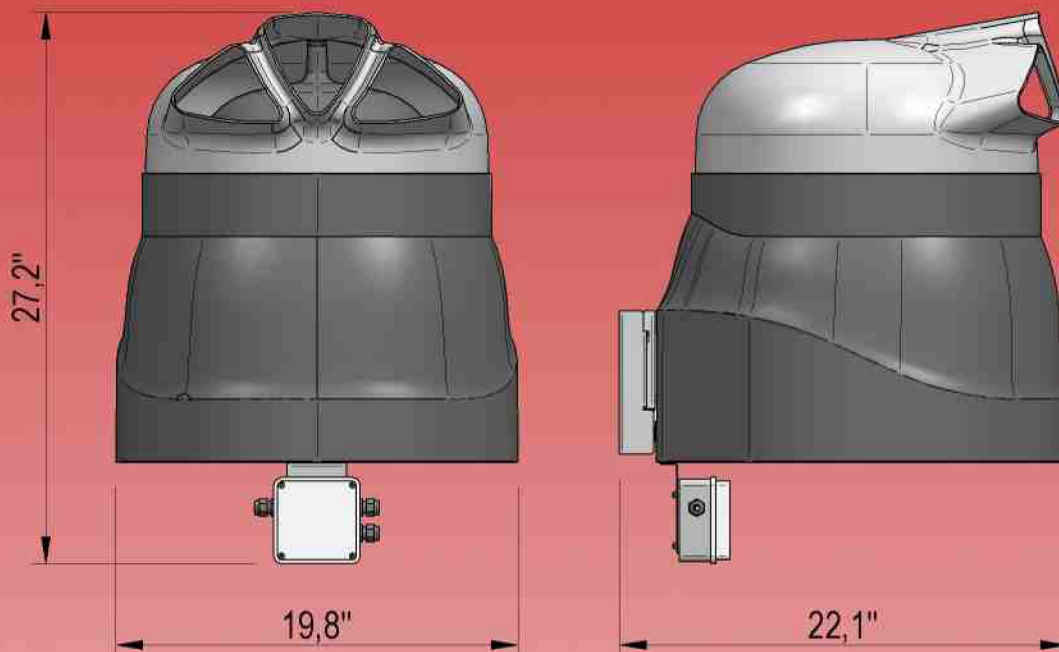

INTRODUCTION

The NEB 6500 is a room humidifier that uses the principle of centrifugal force to atomise water. It is therefore self-standing and needs no additional equipment such as high-pressure pumps or compressed air. The operating principle, that makes it practically insensitive to calcium deposits, and its simple and robust construction, allows it to operate with any kind of water, whether demineralised or drinking water. It produces a very fine mist that is blown into the surrounding air where it evaporates and humidifies it.

FEATURES

- ◆ Water basin of very small dimensions (water content 0,12 lbs).
- ◆ The basin is emptied at the end of the cycle. Operation with running water and no stagnant water deposits, resulting in maximum hygiene.
- ◆ Large atomisation capacity: 14,3 lbs/hr. The capacity can be easily adjusted from between 13% and 100% of the maximum capacity.
- ◆ Operation with tap or demineralized water.
- ◆ Anti-freeze heater (only NEB6500R model).
- ◆ Great flexibility and therefore it can be adapted to all applications.
- ◆ Simple and sturdy construction.

- ◆ Installation accessories such as wall mountings, hanging brackets, connection pipes, nuts and bolts, etc. are supplied as standard. Easy installation and maintenance.
- ◆ Low power absorption: only 220 W (290W with heater).
- ◆ Built with materials that can be easily recycled. Low operating costs and respect for the environment.
- ◆ Comply with US and Canadian standard.

APPLICATIONS

It is most often used in: cold storage warehouses for fruit and vegetables, printing houses, textile industries, germination cells, hot-houses, seasoning cells.

TECHNICAL DATA

Power supply	~120 V, 60 Hz
Rated current [A]	0,9
Air flow [cfm]	164,8
Atomization capacity [lbs/hour]	3,3...14,3
Feed water pressure [psi]	14,5...145
Water content [lbs]	0,12
Working temperature [°F] (with heater)	+33,4 (+28,4)...+95
Working humidity [%r.h.]	0...100 (non condensing)
Dry weight [lbs]	38,8

The above data are subject to change without notice.